

1.9mm Round Subminiature“ Z-Bend” Lead Photodiode PD95-21B/TR10



Features

- Fast response time
- High photo sensitivity
- Small junction capacitance
- Compatible with infrared and vapor phase reflow solder process.
- Pb free
- The product itself will remain within RoHS compliant version.

Descriptions

- PD95-21B/TR10 is a high speed and high sensitive PIN photodiode in miniature top view lens SMD package and it is molded in a black plastic .The device is spectrally matched with the infrared emitting diode.

Applications

- Infrared applied system
- Copier
- Sensor in automotive project

Device Selection Guide

Part Category	Chip Material	Lens Color
PD	Silicon	Black

Package Dimensions

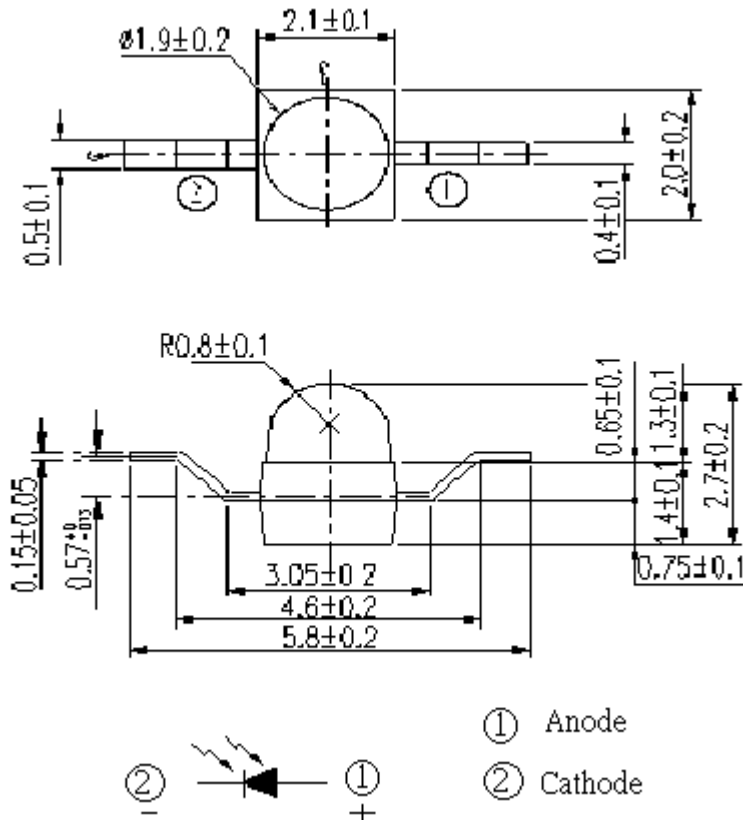

- Notes:** 1.All dimensions are in millimeters
2.Tolerances unless dimensions ± 0.1 mm

Absolute Maximum Ratings ($T_a=25^\circ\text{C}$)

Parameter	Symbol	Rating	Units
Reverse Voltage	V_R	32	V
Operating Temperature	T_{opr}	-25 ~ +85	
Storage Temperature	T_{stg}	-40 ~ +85	
Soldering Temperature *1	T_{sol}	260	
Power Dissipation at(or below) 25 Free Air Temperature	P_d	150	mW

Notes: *1:Soldering time 5 seconds.

Electro-Optical Characteristics (Ta=25)

Parameter	Symbol	Condition	Min	Typ	Max	Unit
Rang of Spectral Bandwidth	0.5	---	730	---	1100	nm
Wavelength of Peak Sensitivity	p	---	---	940	---	nm
Short-Circuit Current	I _{SC}	Ee=1mW/cm ² p=875nm	---	4	---	μ A
Reverse Light Current	I _L	Ee=1mW/cm ² p=875nm V _R =5V	1	4	---	μ A
Reverse Dark Current	I _D	Ee=0mW/cm ² V _R =10V	---	---	10	nA
Reverse Breakdown Voltage	V _{BR}	Ee=0mW/cm ² I _R =100 μ A	32	170	---	V

Typical Electro-Optical Characteristics Curves

Fig.1 Spectral Sensitivity

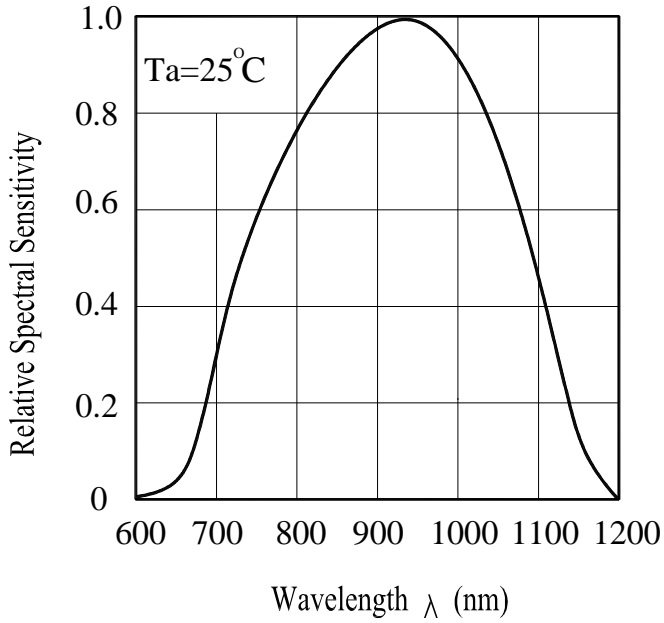
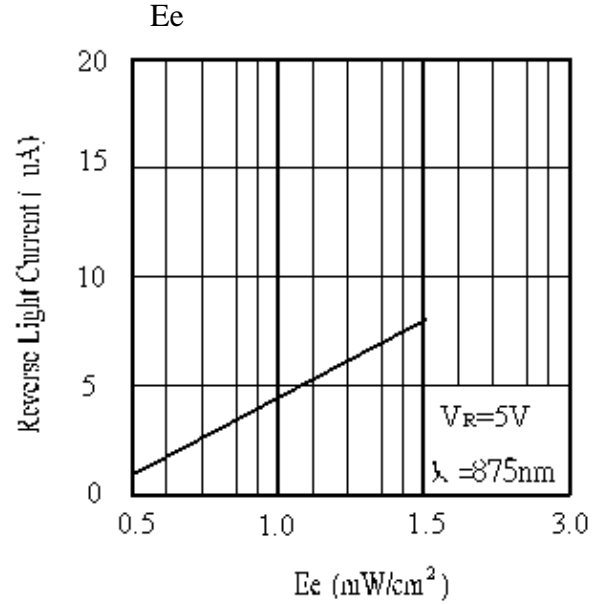

Fig.2 Reverse Light Current vs. E_e



Precautions For Use

1. Over-current-proof

Customer must apply resistors for protection , otherwise slight voltage shift will cause big current change (Burn out will happen).

2. Storage

2.1 Do not open moisture proof bag before the products are ready to use.

2.2 Before opening the package, the LEDs should be kept at 30% or less and 90%RH or less.

2.3 The LEDs should be used within a year.

2.4 After opening the package, the LEDs should be kept at 30% or less and 70%RH or less.

2.5 The LEDs should be used within 168 hours (7 days) after opening the package.

2.6 If the moisture absorbent material (silica gel) has faded away or the LEDs have exceeded the storage time, baking treatment should be performed using the following conditions.

Baking treatment : 60 ± 5 for 24 hours.

3. Soldering Condition

3.1 Pb-free solder temperature profile

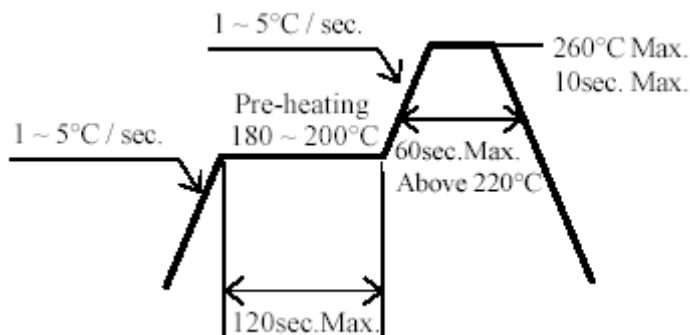

3.2 Reflow soldering should not be done more than two times.

3.3 When soldering, do not put stress on the LEDs during heating.

3.4 After soldering, do not warp the circuit board.

4.Soldering Iron

Each terminal is to go to the tip of soldering iron temperature less than 350 for 3 seconds within once in less than the soldering iron capacity 25W. Leave two seconds and more intervals, and do soldering of each terminal. Be careful because the damage of the product is often started at the time of the hand solder.

5.Repairing

Repair should not be done after the LEDs have been soldered. When repairing is unavoidable, a double-head soldering iron should be used (as below figure). It should be confirmed beforehand whether the characteristics of the LEDs will or will not be damaged by repairing.

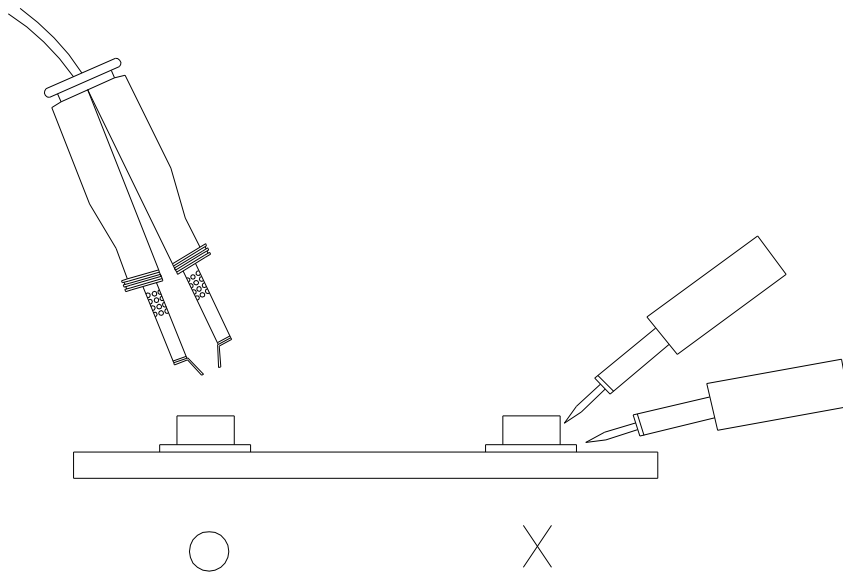

Package Dimensions

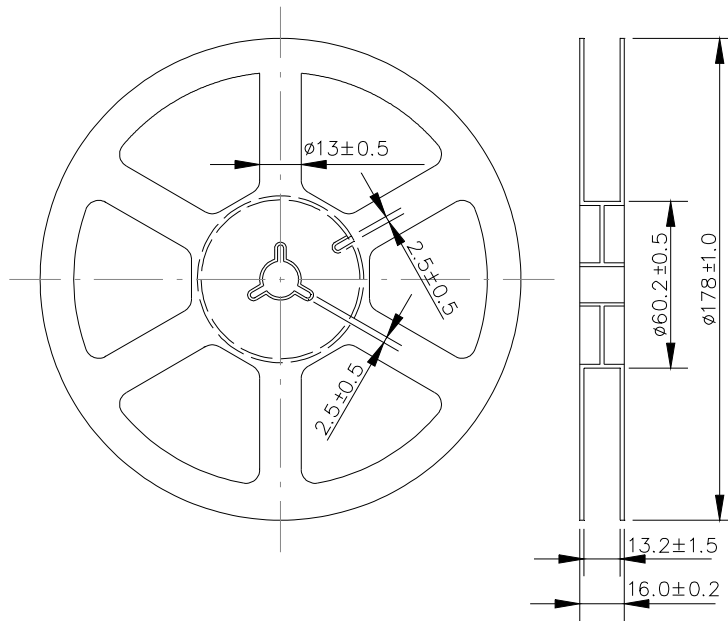

Note: The tolerances unless mentioned are ± 0.1 , unit=mm.

Carrier Tape Dimensions: (Quantity: 1000PCS/Reel)

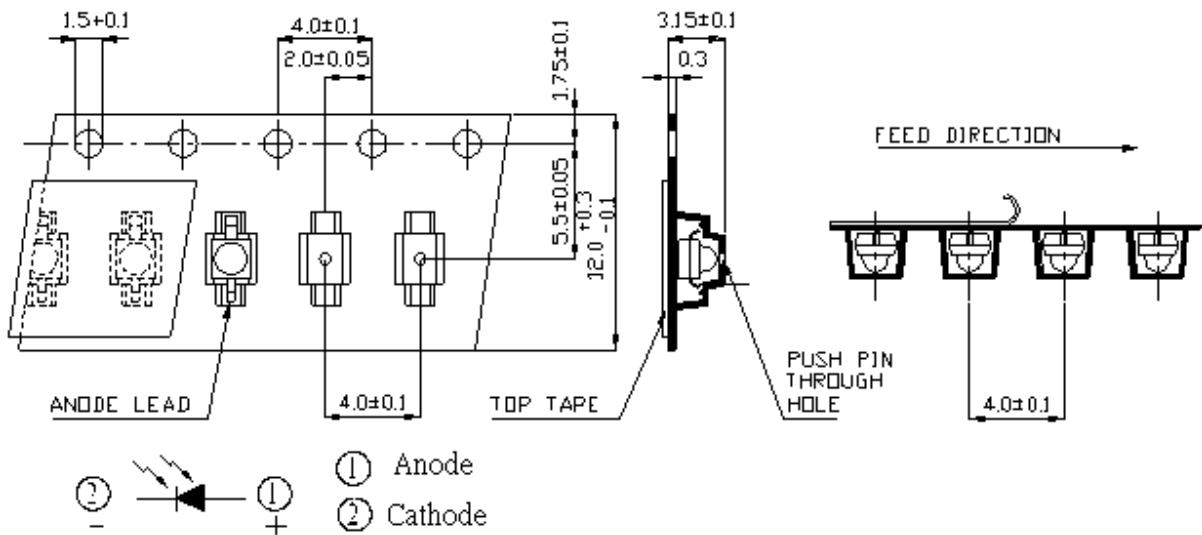

Note: The tolerances unless mentioned are ± 0.1 , unit=mm.

Label Form Specification

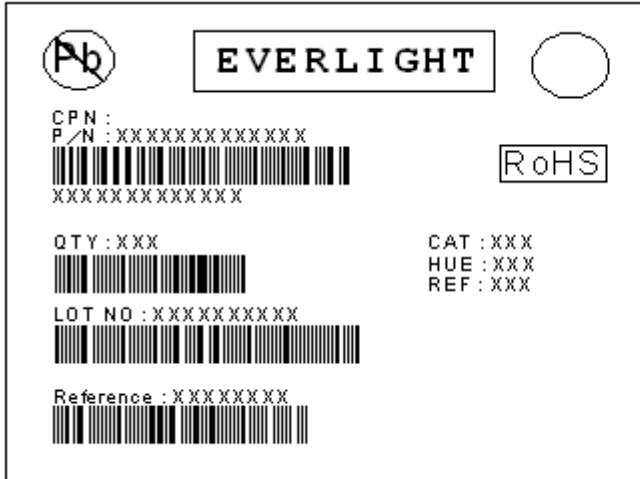

CPN: Customer's Production Number[↵]

P/N: Production Number[↵]

QTY: Packing Quantity[↵]

CAT: Ranks[↵]

HUE: Peak Wavelength[↵]

REF: Reference[↵]

LOT No: Lot Number[↵]

Notes

1. Above specification may be changed without notice. EVERLIGHT will reserve authority on material change for above specification.
2. When using this product, please observe the absolute maximum ratings and the instructions for using outlined in these specification sheets. EVERLIGHT assumes no responsibility for any damage resulting from use of the product which does not comply with the absolute maximum ratings and the instructions included in these specification sheets.
3. These specification sheets include materials protected under copyright of EVERLIGHT corporation. Please don't reproduce or cause anyone to reproduce them without EVERLIGHT's consent.

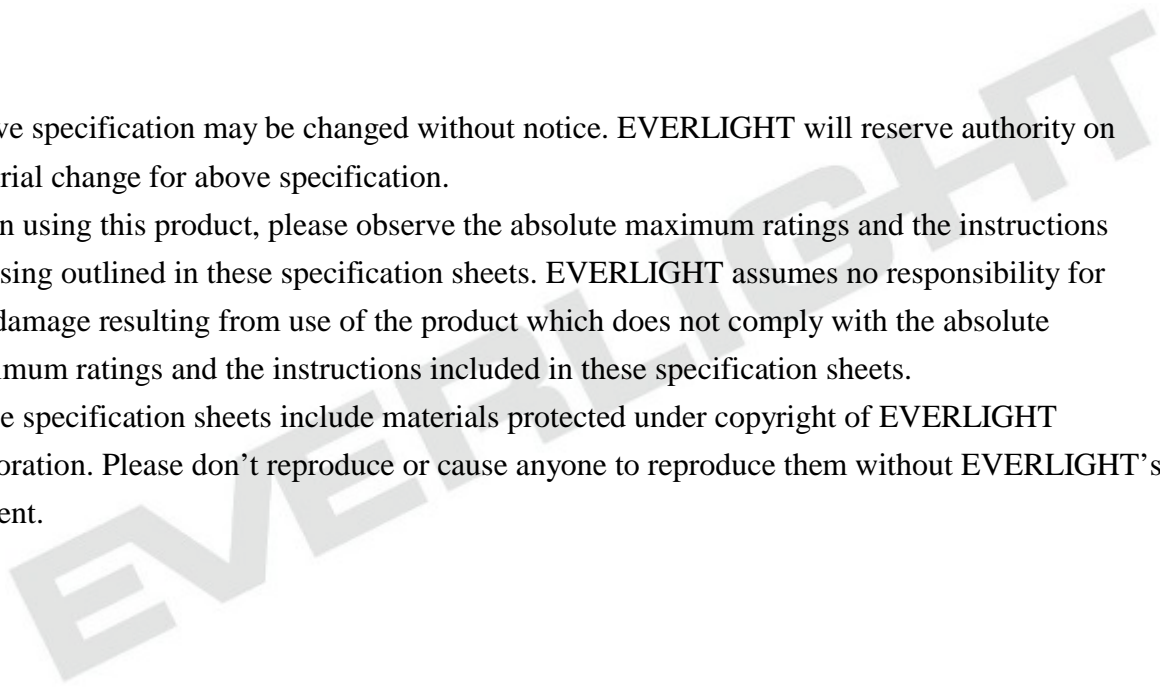

EVERLIGHT ELECTRONICS CO., LTD.

Office: No. 6-8, Zhonghua Rd., Shulin Dist.,

New Taipei City 23860, Taiwan

Tel: 886-2-2685-6688

Fax: 886-2685-2699 , 6897

<http://www.everlight.com>