



MODEL NO: 19-21SUGC/TR8

Device Number : DSE-191-061 REV. 1.0

0.8mm Height Flat Top LEDs

ECN : _____ Page: 1/8

Features :

- Package in 8mm tape on 7" diameter reel.
- Compatible with automatic placement equipment.
- Compatible with infrared and vapor phase reflow solder process.
- Mono-color type.

Descriptions :

- The 19-21 SMD Taping is much smaller than leaded components, thus enable smaller board size, higher packing density, reduced storage space and finally smaller equipment to be obtained.
- Besides, lightweight makes them ideal for miniature application, etc.

Applications :

- Automotive: backlighting in dashboard and switch.
- Telecommunication: indicator and backlighting in telephone and fax
- Flat backlight for LCD, switch and symbol.
- General use.

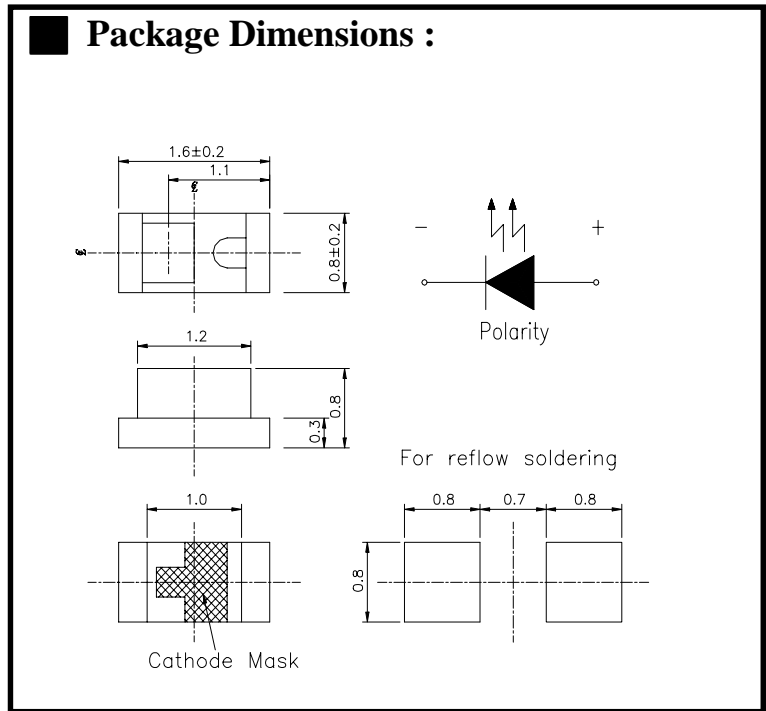

Notes :

Tolerances Unless Dimension $\pm 0.1\text{mm}$
 Angle $\pm 0.5^\circ$
 Unit = mm

PART NO	CHIP		Lens Color
	Material	Emitted Color	
19-21SUGC/TR8	GaN	Super Green	Water Clear

Office: NO 25,Lane.76, Chung Yang Rd., Sec.3, Tucheng, Taipei 236, Taiwan, R.O.C.

TEL: 886-2-2267-2000,2266-9936(22 Lines)

FAX: 886-2-2267-6189

<http://www.everlight.com>



MODEL NO: 19-21SUGC/TR8

Device Number : DSE-191-061 REV. 1.0

0.8mm Height Flat Top LEDs

ECN : _____ Page: 2/8

Package Dimensions :

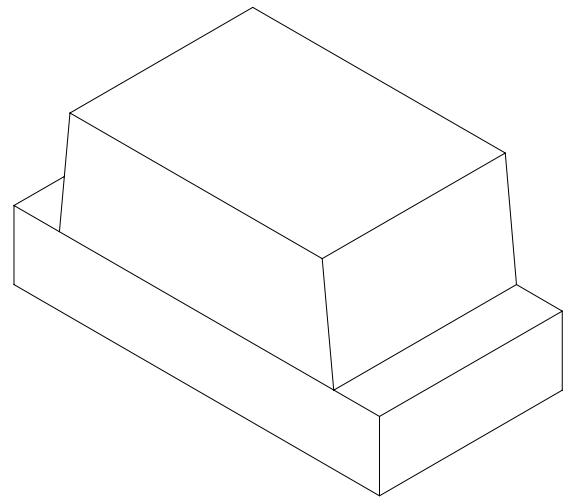
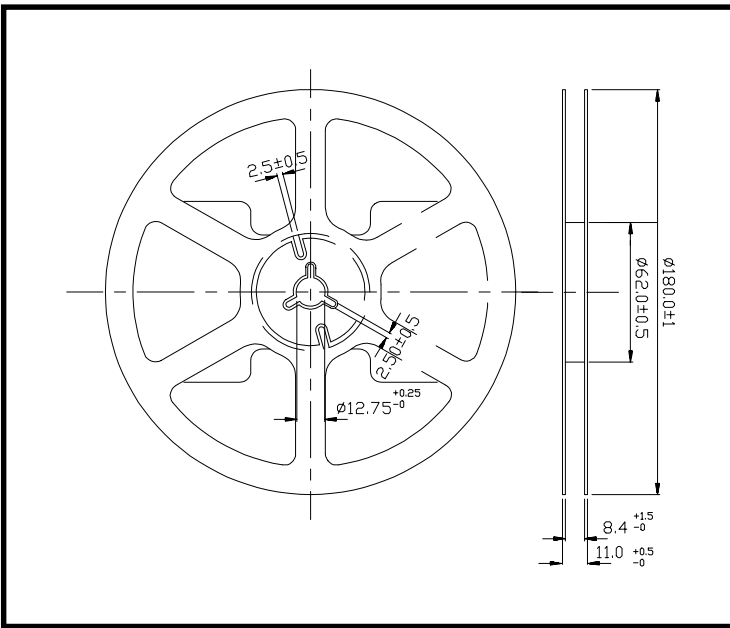

Loaded quantity per reel 3000 pcs/reel :

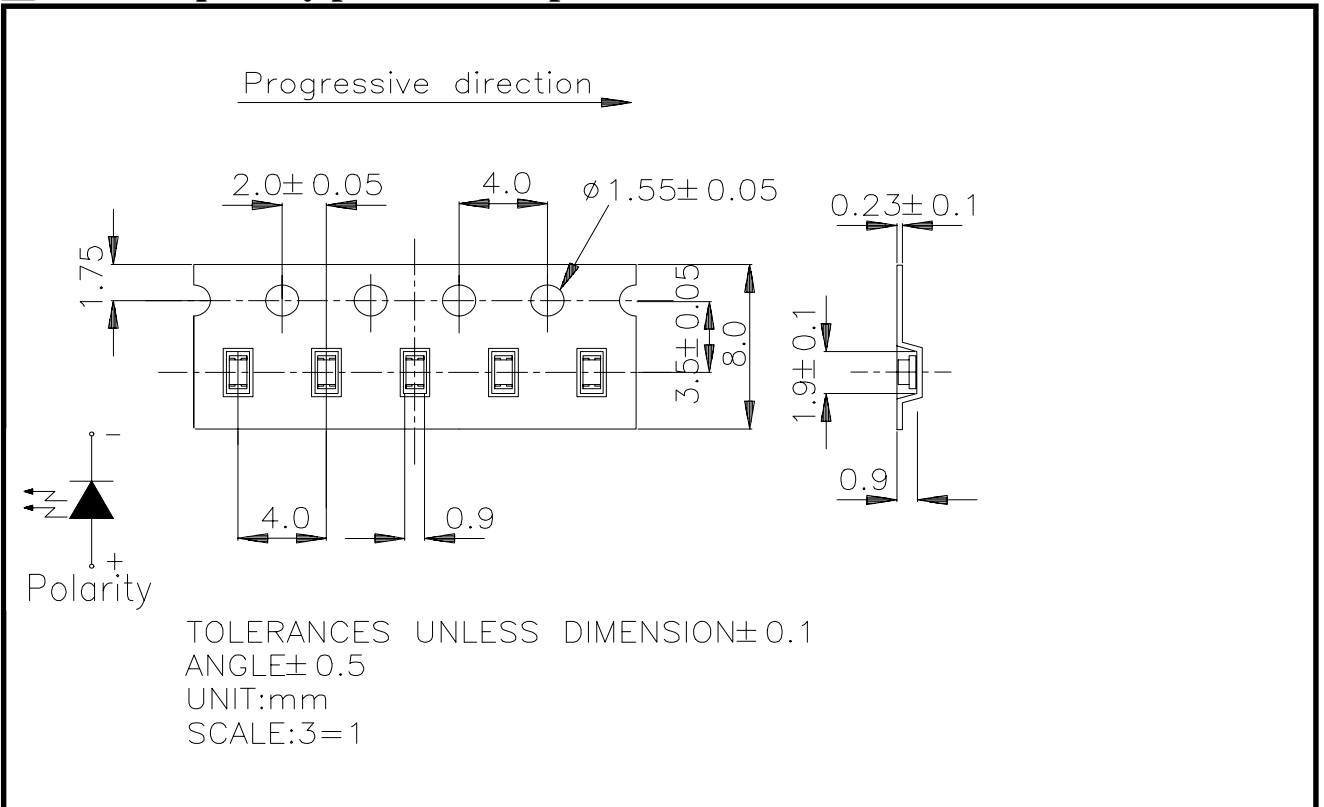



MODEL NO: 19-21SUGC/TR8

Device Number : DSE-191-061 REV. 1.0

0.8mm Height Flat Top LEDs

ECN : _____ Page: 3/8

■ Absolute Maximum Ratings at Ta = 25°C

Parameter	Symbol	Rating	Unit
Reverse Voltage	Vr	5	V
Forward Current	If	30	mA
Operating Temperature	Topr	-40 ~ +85	°C
Storage Temperature	Tstg	-40 ~ +90	°C
Soldering Temperature	Tsol	260 (for 5 second)	°C
Electrostatic Discharge	ESD	150	V
Power Dissipation	Pd	120	mW
Peak Forward Current(Duty 1/10 @ 1KHZ)	If(Peak)	100	mA

■ Electronic Optical Characteristics :

Parameter	Symbol	Min.	Typ.	Max.	Unit	Condition
Luminous intensity	Iv	100	160	-----	mcd	If=20mA
Viewing Angle	2θ 1/2	-----	120	-----	deg	If=20mA
Peak Wavelength	λp	-----	525	-----	nm	If=20mA
Dominant Wavelength	λd	-----	530	-----	nm	If=20mA
Spectrum Radiation Bandwidth	Δλ	-----	35	-----	nm	If=20mA
Forward Voltage	Vf	3.1	3.5	4.0	V	If=20mA
Reverse Current	Ir	-----	-----	50	μA	Vr=5V



MODEL NO: 19-21SUGC/TR8

Device Number : DSE-191-061 REV. 1.0

0.8mm Height Flat Top LEDs

ECN : _____ Page: 4/8

Reliability Test Item And Condition

NO	Item	Test Conditions	Test Hours/Cycle	Sample Size	Ac/Re
1	Solder Heat	TEMP : 260°C ± 5 °C	5 SEC	76 Pcs	0/1
2	Temperature Cycle	H : +85°C 30min ∫ 5 min L : -55°C 30min	50 CYCLE	76 Pcs	0/1
3	Thermal Shock	H : +100°C 5min ∫ 10 sec L : -10°C 5min	50 CYCLE	76 Pcs	0/1
4	High Temperature Storage	TEMP : 100°C	1000 HRS	76 Pcs	0/1
5	Low Temperature Storage	TEMP : -55°C	1000 HRS	76 Pcs	0/1
6	DC Operating Life	If = 20 m A	1000 HRS	76 Pcs	0/1
7	High Temperature / High Humidity	85°C/85% RH	1000 HRS	76 Pcs	0/1



MODEL NO: 19-21SUGC/TR8

Device Number : DSE-191-061 REV. 1.0

0.8mm Height Flat Top LEDs

ECN : _____ Page: 5/8

Typical Electro-Optical Characteristic Curves

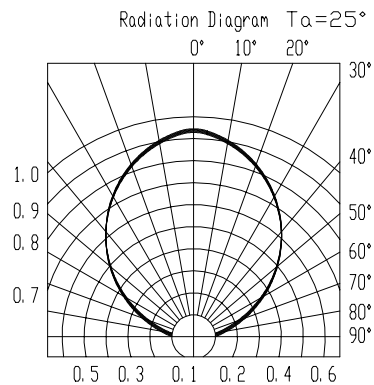
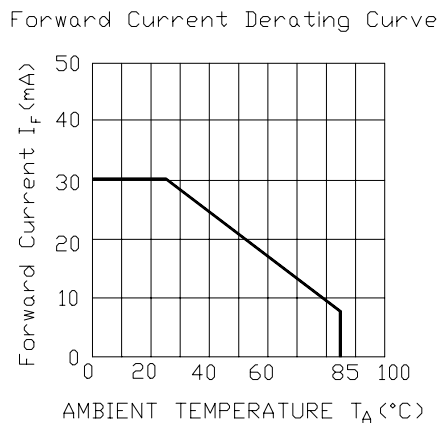
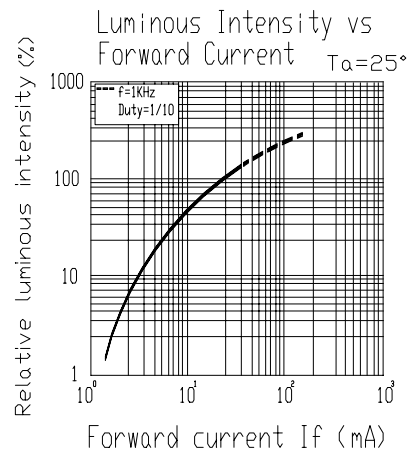
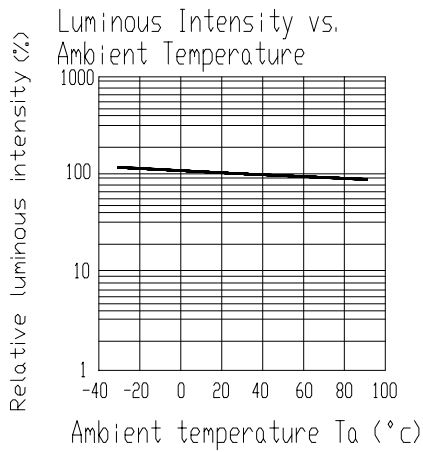
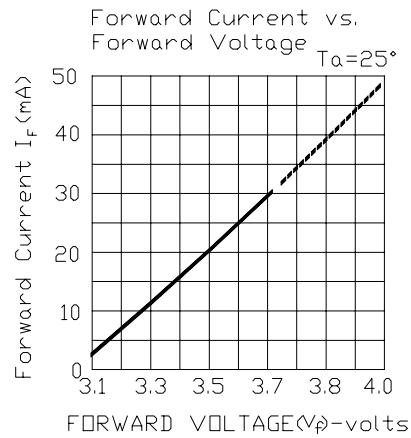
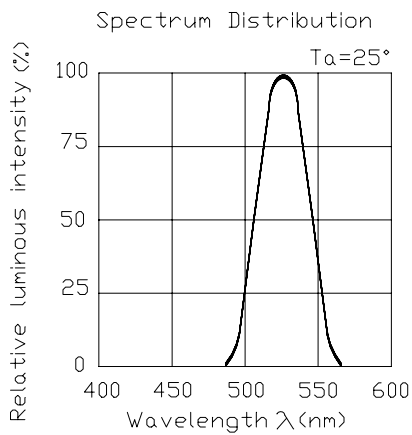



EVERLIGHT ELECTRONICS CO., LTD.

MODEL NO: 19-21SUGC/TR8
0.8mm Height Flat Top LEDs

Device Number : DSE-191-061 REV. 1.0

ECN : Page: 6/8

■ Test Circuit

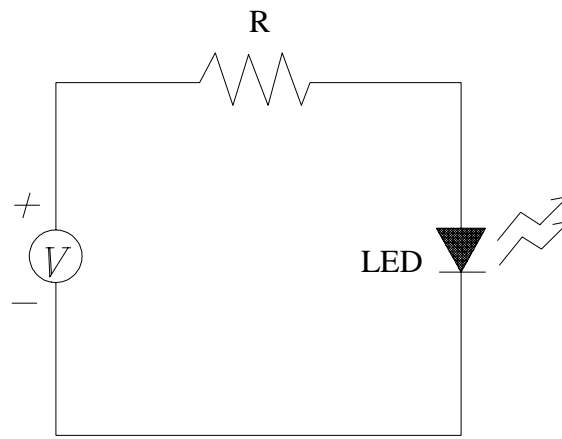

■ Precautions For Use

1. Over-current-proof

Customer must apply resistors for protection , otherwise slight voltage shift will cause big current change (Burn out will happen).

2. Storage time

2.1 The operation of temperature and R.H. are : $5^{\circ}\text{C} \sim 35^{\circ}\text{C}$, R.H.60%.

2.2 Once the package is opened , the products should be used within a week.
Otherwise , they should be keep in a dampproof box with desiccants.
Considering the tape life , we suggest our customers to use our products within a year(from production date).

2.3 If opened more than one week in an atmosphere $5^{\circ}\text{C} \sim 35^{\circ}\text{C}$, R.H.60% , they should be treated at $60^{\circ}\text{C} \pm 5^{\circ}\text{C}$ for 15hrs.

2.4 When you discover that the desiccant in the package has a pink color (normal=blue) , you should treat them in the same conditions as 2.3.

■ **Soldering heat reliability (DIP)**

Please refer to the following figure :

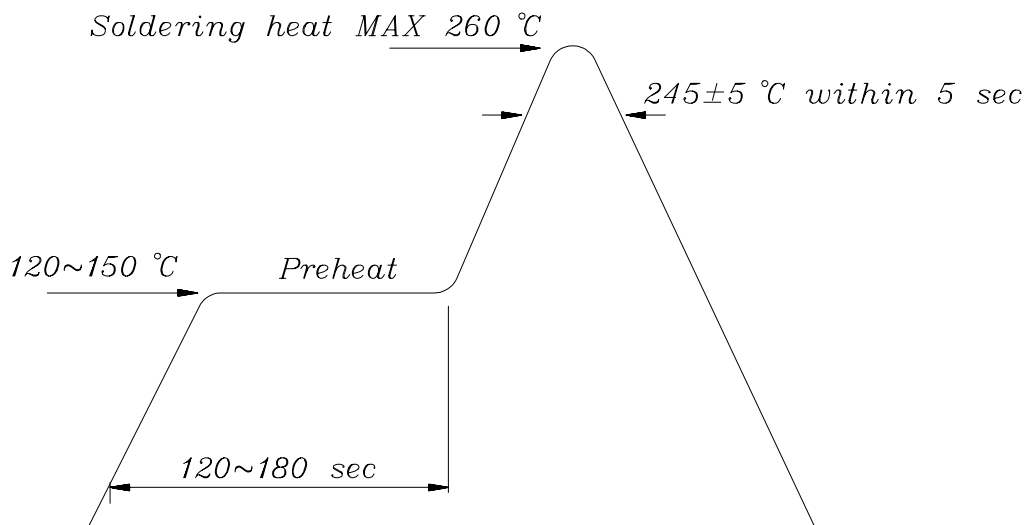

■ **Soldering Iron**

Basic spec is ≤ 5 sec when 260°C . If temperature is higher, time should be shorter ($+10^{\circ}\text{C} \rightarrow -1\text{sec}$). Power dissipation of iron should be smaller than 15 W , and temperature should be controllable. Surface temperature of the device should be under 230°C .

■ **Rework**

1. Customer must finish rework within 5 sec under 260°C .
2. Copper foil can not be touched by the head of iron.
3. Twin-head type is preferred.

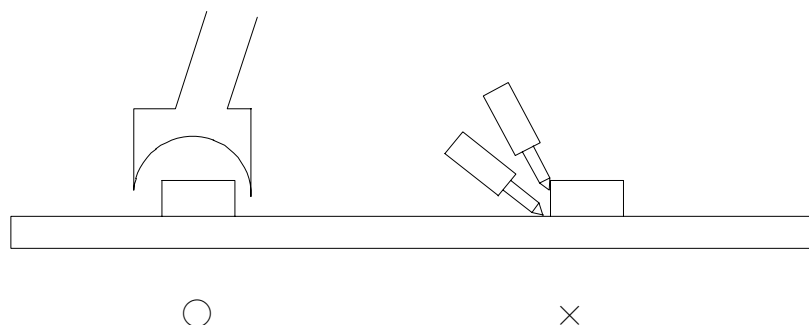



MODEL NO: 19-21SUGC/TR8

Device Number : DSE-191-061 REV. 1.0

0.8mm Height Flat Top LEDs

ECN : Page: 8/8

■ Reflow Temp / Time :

